

TYPE FC

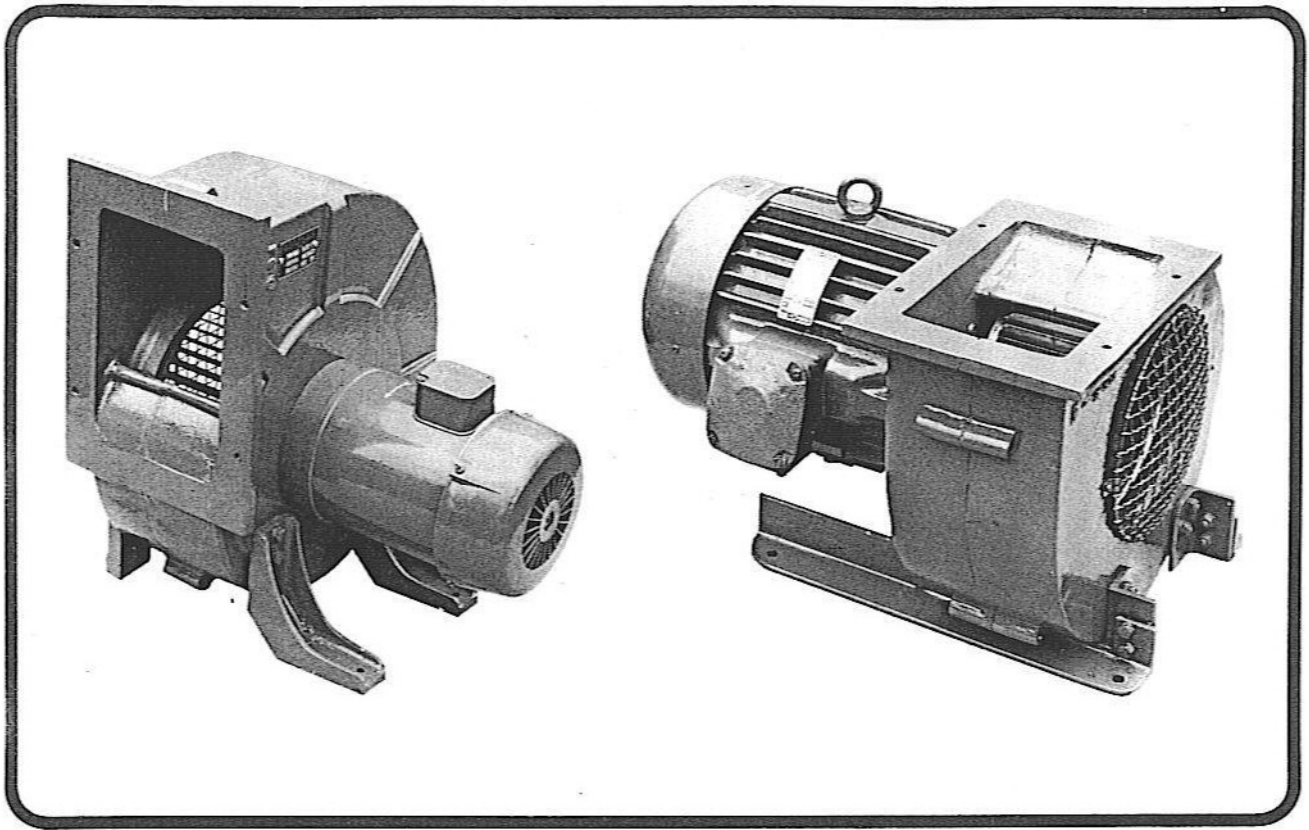

These units — covering the output range shown in the graph below — are supplied with driving motors, between 0.1 and 7.5 h.p. at 1425 or 2850 r.p.m. as standard.

The motors, which are flange mounted to the casing which has a machined spigot to suit, can also be at 930 or 700 r.p.m. Indirect driven units for operating at all intermediate speeds, are available.

Eleven different casing sizes constructed of cast aluminium, with various widths and both right and left handings are included in this range.

Impellers are the forward curved type constructed of zinc plated steel and accurately balanced.

Mounting fixtures are available in various types (two are illustrated) and special mountings can be fitted to suit specific requirements.

The outlet position can be rotated through 360° on assembly.

Inlet guards, or extensions and adaptors on outlets can be fitted as the casings may be drilled or tapped for easy fitting of all accessories.

